

2 -Wire Intercom System

DT16 User Manual

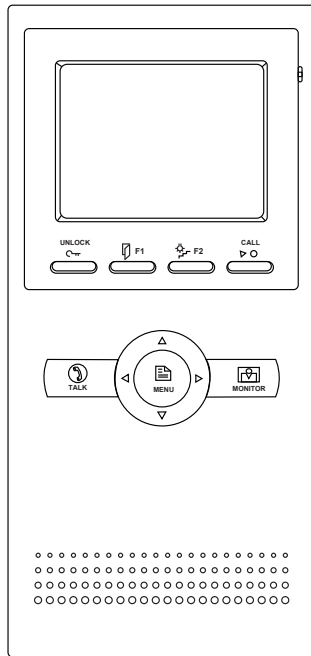

PRECAUTIONS

- Please read this manual through before using the product.
- Don't install or make any wire terminations while power supply is plugged in. It can cause electrical shock or damage to the unit.
- All parts should be protected from violence vibration. And don't allow to be impacting, knocking and dropping.
- For clean the LCD screen, using hands or wet cloth is forbidden.
- Please do the cleanness with soft cotton cloth, don't use the organic or chemical clean impregnate. If necessary, use pure water or dilute soap water to clean the dust.
- Image distortion may occur if the video door phone is mounted too close to magnetic field e. g. Microwaves, TV, computer etc.
- Please keep away the video door monitor from wet, high temperature, dust, caustic and oxidation gas in order to avoid any unpredictable damage.
- Don't open the device at any condition, call for help if there are any problems.

CONTENTS

1.Parts and Functions	1
2.Monitor Mounting	2
3.System Connection	3
4.Operations.....	4
4.1 Answering a door call	4
4.2 Door release.....	4
4.3 Entrance monitoring	5
4.4 Intercom function.....	5
4.5 Image and Volume Adjust	5
4.6 Basic Setup Instructions.....	6
5.Specifications	8

1.Parts and Functions

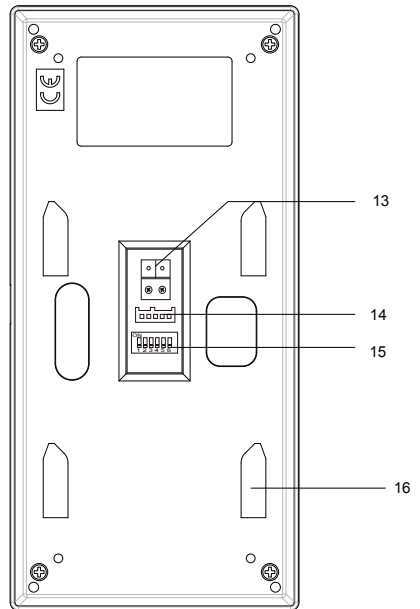
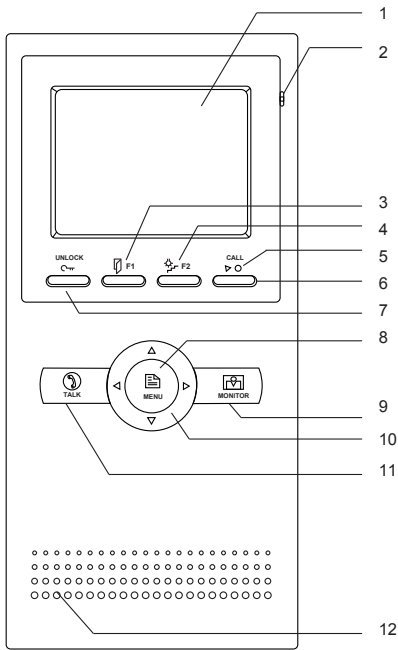

1. LCD Screen
2. Microphone
3. Second UNLOCK Button
4. Staircase Light Button
5. LED Indicator
6. CALL Button
7. UNLOCK Button
8. MENU Button
9. MONITOR Button

10. Direction Button
11. TALK Button
12. Speaker
13. Connection Port
14. Extend Port
15. DIP Switches
16. Mounting Hook

2. Monitor Mounting

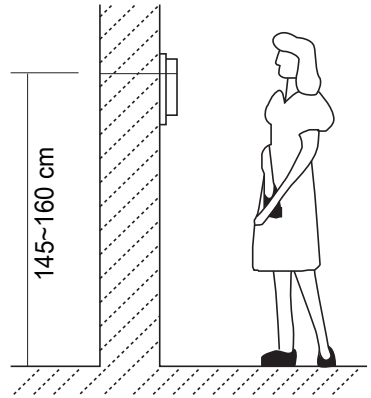
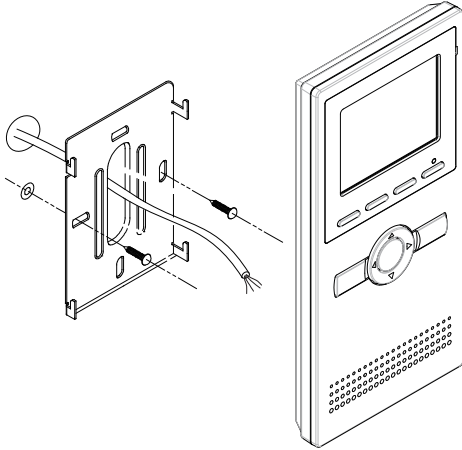

1. Use the screws to fix the Mounting Bracket on the mounting box.(fitting accesories includes a Bracket (Two pieces of 4X25 screws are needed for fastening the Mounting Bracket), Special 2 wire cables to connect with Monitor)
2. Wire the system correctly(see the later connection chapter) then hang the Monitor on the Mounting Bracket firmly.

3. Monitor Extending Connection

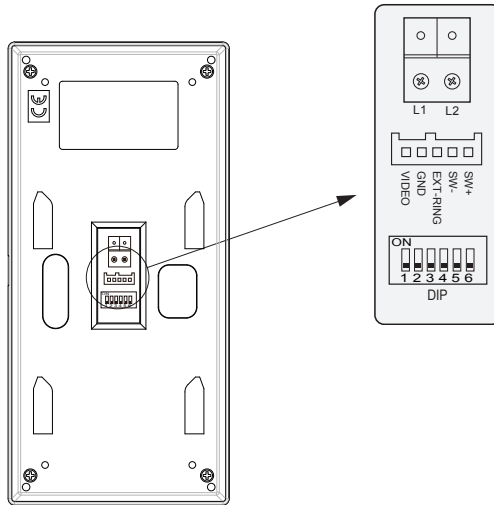

1. Door Bell Call Button

Additional door bell call button can be connected to the Monitor, so that the visitors can ring the door bell again in front of the user's apartment. When the call button is pressed, the Monitor will output ring tones but the screen will keep off, and the external ringer will ring at the same time (if a external ringer is installed).

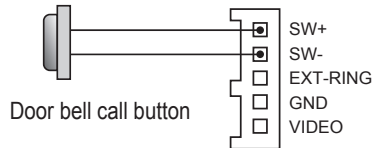

2. External Ringer

External ringer can be connected to the Monitor. The ringer will ring whenever the Door Station call button or the door bell call button is pressed, and it will stop ringing when the Monitor rejected or answered the call.

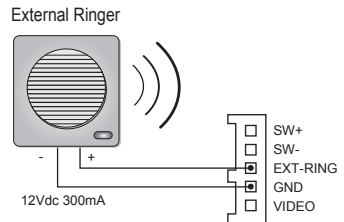

4.Operations

4.1 Answering a door call

1. Press "CALL" button on doorstation.
2. The monitor rings,and the visitor will be seen on video monitor.
note: the screen turns off after 40 seconds if nobody answers.(40 seconds is default,it can be set by yourself)

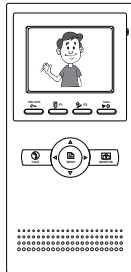

3. Press "TALK" button,you can communicate hands free with the visitor for 90 seconds.
After finishing communication,press "TALK" button again to end the communication.



4.2 Door release

1. During communication,press "UNLOCK" button to release the door.(If two locks connected to door camera,press a lock button to open the matching lock)

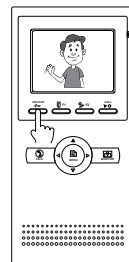

4.3 Entrance monitoring

1. Press "MONITOR" button when in standby.
2. The screen will display the image from door station.
3. Press "MONITOR" button again to end monitoring.

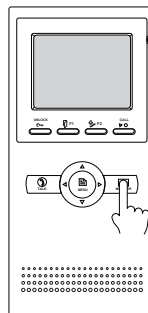

4.4 Intercom function

1. Press "CALL" button in standby mode to enter intercom function page.
2. **Intercom Call:** User in one apartment can call other apartments in the system. Use ▲ / ▼ to select the item and press MENU button to enter the **Name List** page. (the namelist will be created automatically by the system). Selete a name on the screen then press CALL Button to call. Use ▲ / ▼ button to scroll to Last / Next name list page.
 note: 1. Press "CALL" button again to redial. 2. Press "TALK" button to cancel the call.
3. **Inner Call:** If multi Monitors are installed in the same apartment, select Inner Call all the other Monitors will ring at the same time, whichever Monitor answers the call, conversation is started.
4. **Direct Dial Guard unit:** A Monitor can be assigned as Guard Unit Monitor; when the Guard Unit Monitor answers the call, conversation with the guard person is started..

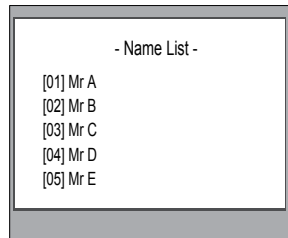
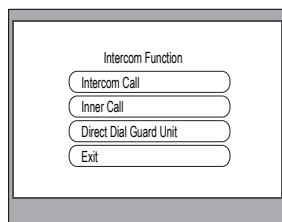

4.5 Image and Volume Adjust



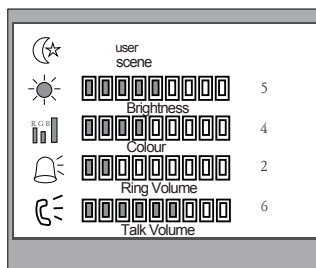





1. During monitoring or talking, press "MENU" button, the **ADJUST MENU** will be displayed.
2. Press ◀ / ▶ to decrease or increase the value; Use ▲ / ▼ button to select the next adjustment item.
3. The first item is Scene mode selection:



Total 4 SCREEN modes can be selected in sequence: **NORMAL**, **USER**, **SOFT** and **BRIGHT**. Whenever you modify **BRIGHTNESS** or **COLOUR**, **SCENE** item will be set to **USER** mode automatically.

4. The **BRIGHTNESS** and **COLOR** item is for the image quality setting, adjust the value to get the best image you like.
5. The **Ring Volume** and **Talk Volume** items are ring tone and talking volume adjustment.
6. Note that all the modifications will be done immediately after the operation. Press "MENU" button to quit the adjust page.

4.6 Basic Setup Instructions

1. Press "MENU" button in standby mode, the date/time page will be displayed. The first line shows the current time, the second line shows the current date and weekday.(the date/time page will close in 3 minutes if no operation).
2. Press "MENU" button again to enter the **MAIN MENU**, Use  /  button to select the **SETUP MENU**, and then press "MENU" button.
3. The **OUTDOOR TONE** and **INTERCOM TONE** item are for chord ring selection. Press  /  to increase/decrease the value. (alternatively, press the item itself in sequence to increase/decrease the value)
4. **AUTO RECORD**: If the item is set to ON, the Monitor will record the image automatically in 2 seconds after the visitor pressed the CALL Button on the Outdoor station.
5. The **ADVANCED SET...** item is for advanced settings. a password will be asked before entering. The default password is **2008**.
6. Press  /  button to increase/decrease the value, Press  /  button to select the location, after finishing, press MENU button to enter next step.

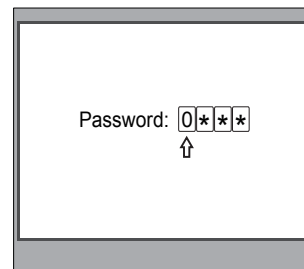
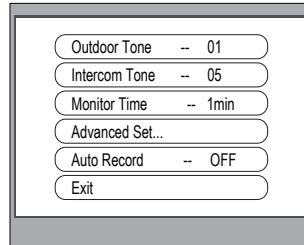
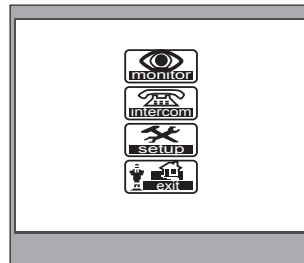
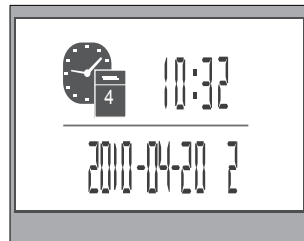

7. The **Slave Addr Set** item is for the master and slave user code setting, if there is only one Monitor installed in one apartment, set to **0**,if there are two,set to 1,if there are three,set to 2,if there are four,set to 3,and the maximum extend monitor is 4.
8. **Guard Unit Set**: if the item is set to **1**, the Monitor is assigned as a Guard Unit Monitor, for normal users, it should be set to **0**.
9. **Date/Time Set...**: Use ▲ / ▼ button to select the item.and then press MENU button to enter time/date setting page.
10. Press ▲ / ▼ button to increase/decrease the value,Press ◀ / ▶ button to select the location,after finishing,press MENU button to save the settings.
11. **Other Settings...**: this item is for adding and deleting Remotes.
12. **Information...**: this item will show the **hardware/software** version and voltage information of the Monitor. Select **Restore to default** item ,then press MENU button. All settings will be restored to default.

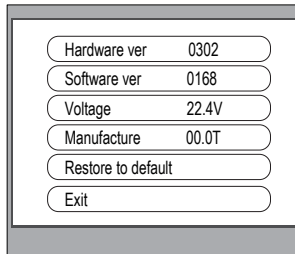
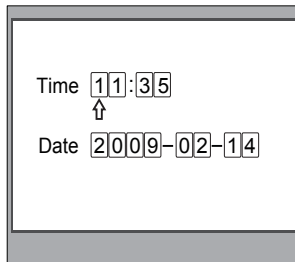
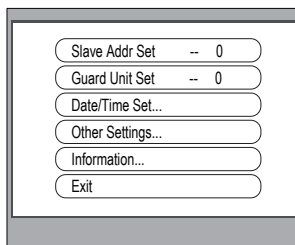

5. Specifications

- Power supply: DC 24V
- Power consumption: Standby 2W; Working 5W
- Monitor screen: 3.5 Inch color TFT-LCD
- Display Resolutions: 320(R, G, B) x 240 pixels
- Dimensions: 220(H)×105(W)×20(D)mm

The design and specifications can be changed without notice to the user. Right to interpret and copyright of this manual are preserved.



DT-ENG-16-V1 100S415